

LINE PROPERTIES

Double head coiling/spooling for single and multi core cables

Developed for coiling and spooling of single /multi core cables with diameter from 3 mm up to 14 mm

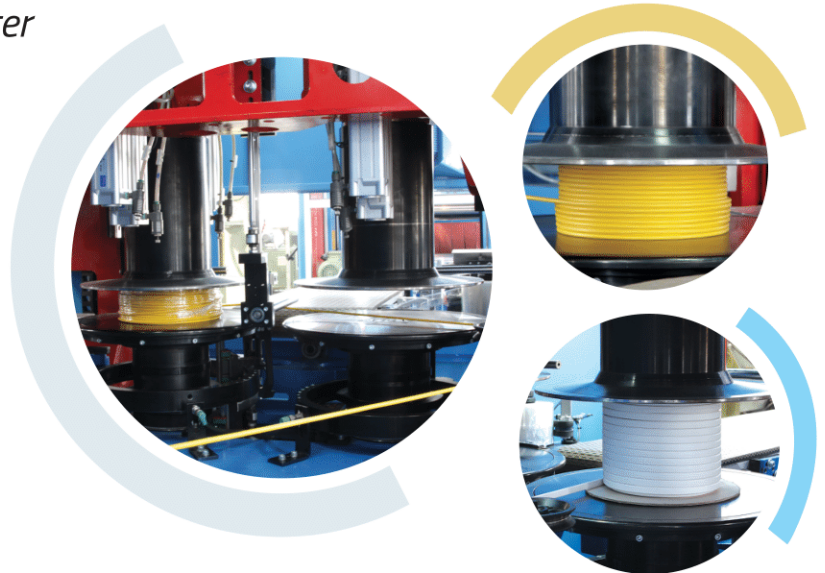
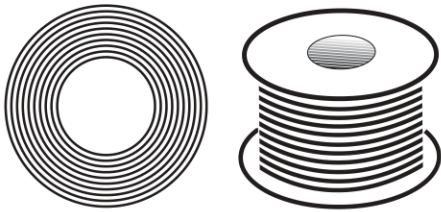

CONFIGURATION

Quadromatik 400 Double head coiler/spooler and stretching unit

- . $\pm 0,15\%$ length tolerance
- . Improved laying up
- . Variable coil outer diameter and height
- . Siemens SIMOTION control system
- . Continuous spark and lump/neckdown control

HB1600 Driven Payoff

- . Suitable for 800mm-1600mm outer reel diameter
- . Minimum change over time
- . Maximum 2.5 ton reel weight

SH800 Shrinking Unit

- . Long life, smokeless cutters
- . Minimum energy consumption
- . Efficient shrinking due to good air ventilation in tunnel

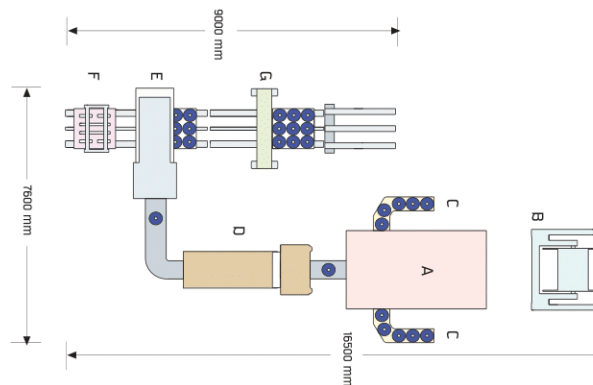

Coil and Spool Dimension

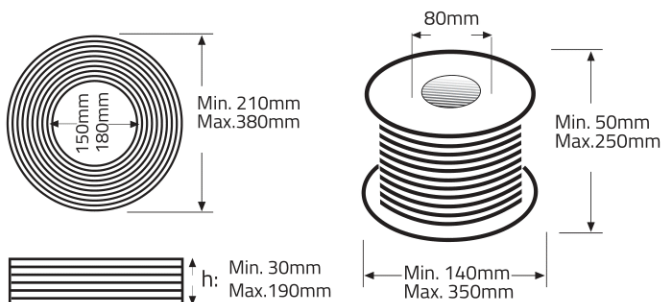

Spool material : Carton, plastic, metal

CABLE TYPE

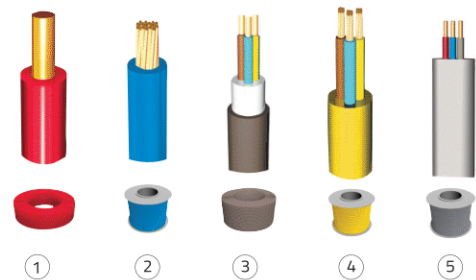

1. Rigid, flexible or multi stranded insulated single wire coiling from 1,5 mm² up to 16 mm²
2. Flexible or rigid multi core cable spooling from 2x0,75 mm² up to 4x2,5 mm²
3. Flat twin and earth type cable spooling from 2x1+1 mm² up to 2x4+2,5 mm²